

1. Introduction

- Massive **scaling up** of hydrogen production through water electrolysis (from several **megawatts** to **gigawatts**) is crucial to meet the growing global hydrogen demand and net-zero future targets.
- At these scales, hydrogen production can be achieved by **interconnecting** numerous electrolysis stacks and **allocating power** across them in a **controlled** and **coordinated** manner.
- This research investigates the key **factors** that matter when scaling-up of hydrogen electrolysis plants and examines the **scale-up requirements**.
- The proposed scaled-up hydrogen electrolyzer (HE) model captures the **operational constraints**, including partial-load and ramp-rate limitations.
- The findings of this study should be considered by **system operators** and **project developers** when planning **system support services** from scaled-up electrolysis plants.

2. Scale-up Strategies and their Electrical Representation

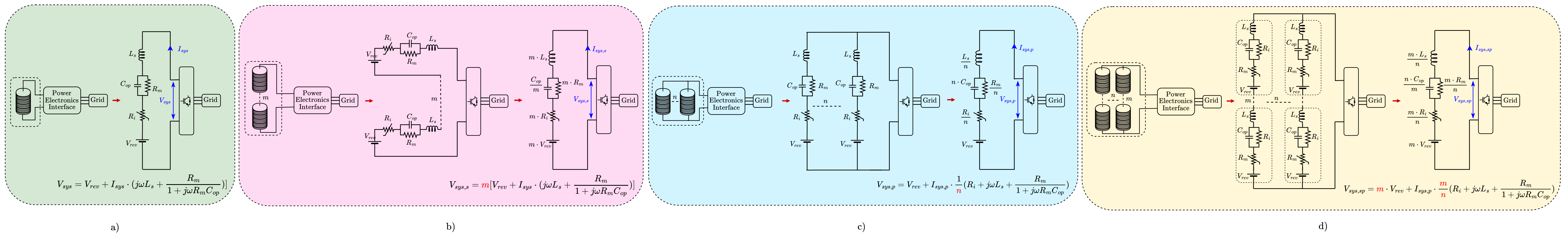

Figure 1: Scale-up strategies: a) single stack, b) series connection, c) parallel connection, d) series-parallel connection.

3. Scaled-up Plant Model

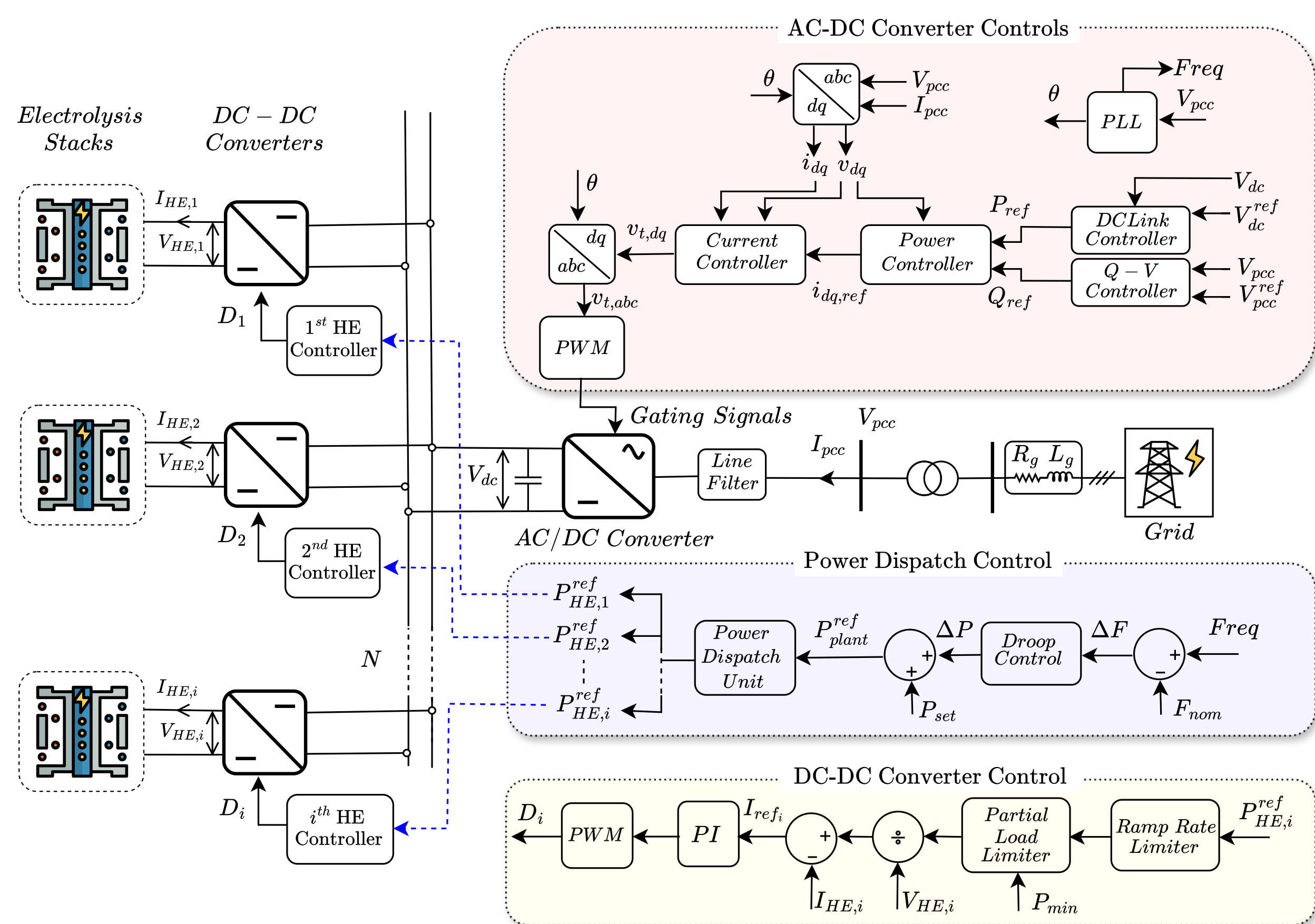

Figure 2: Proposed scaled-up plant model.

4. Simulation Results

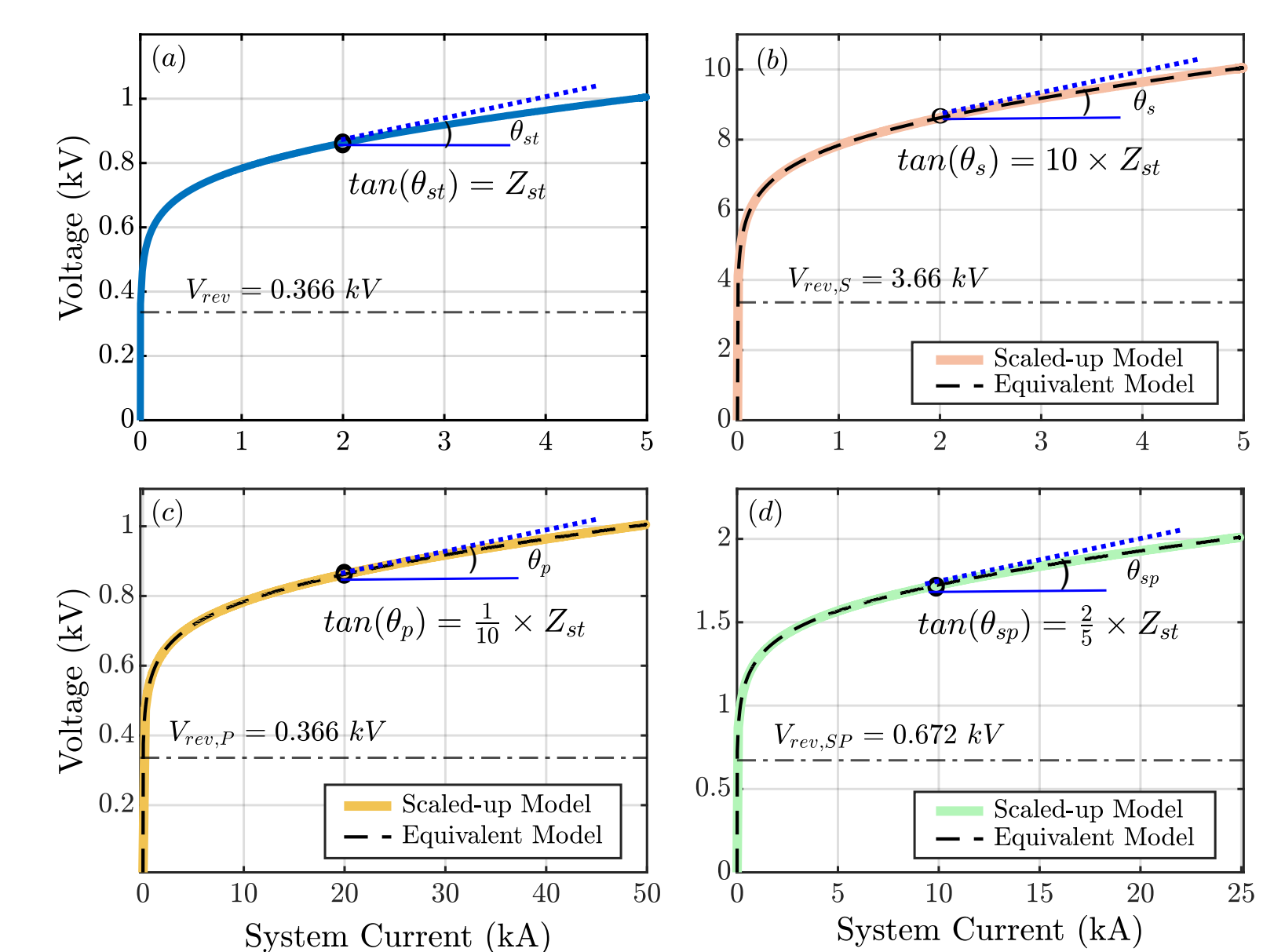

Figure 3: HE V-I curves for different interconnection topologies. a) single stack, b) series connection, c) parallel connection, d) series-parallel connection.

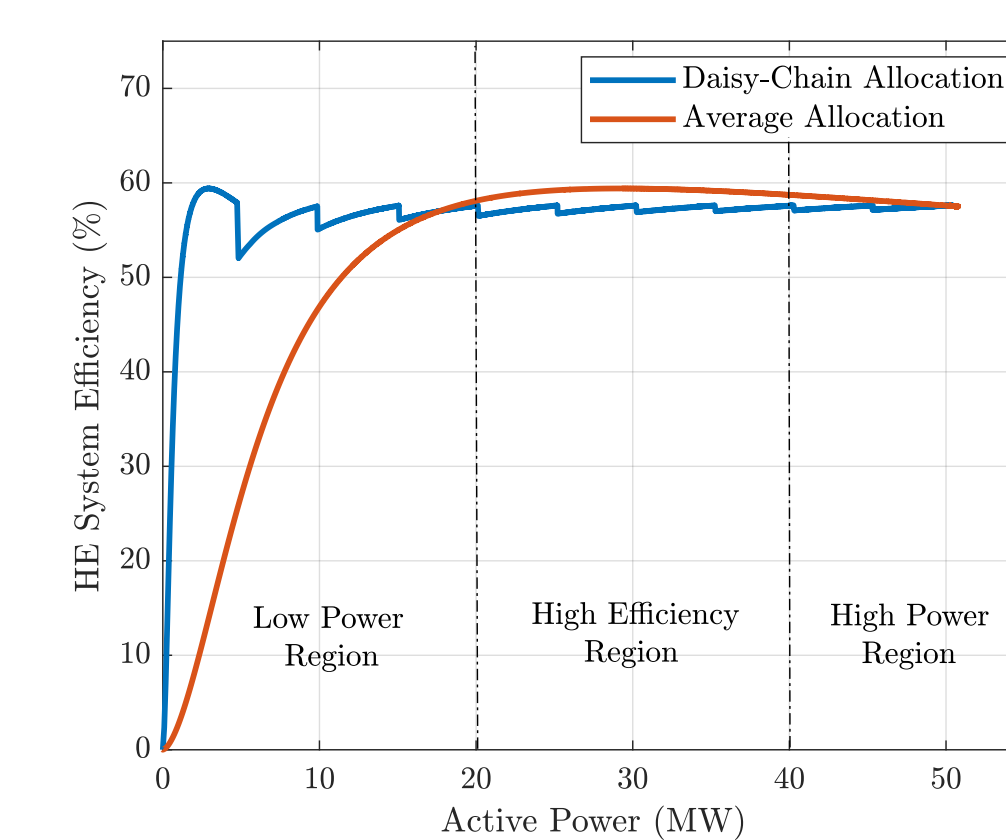

Figure 4: HE system efficiency for different power dispatch strategies.

5. Power Dispatch Strategies

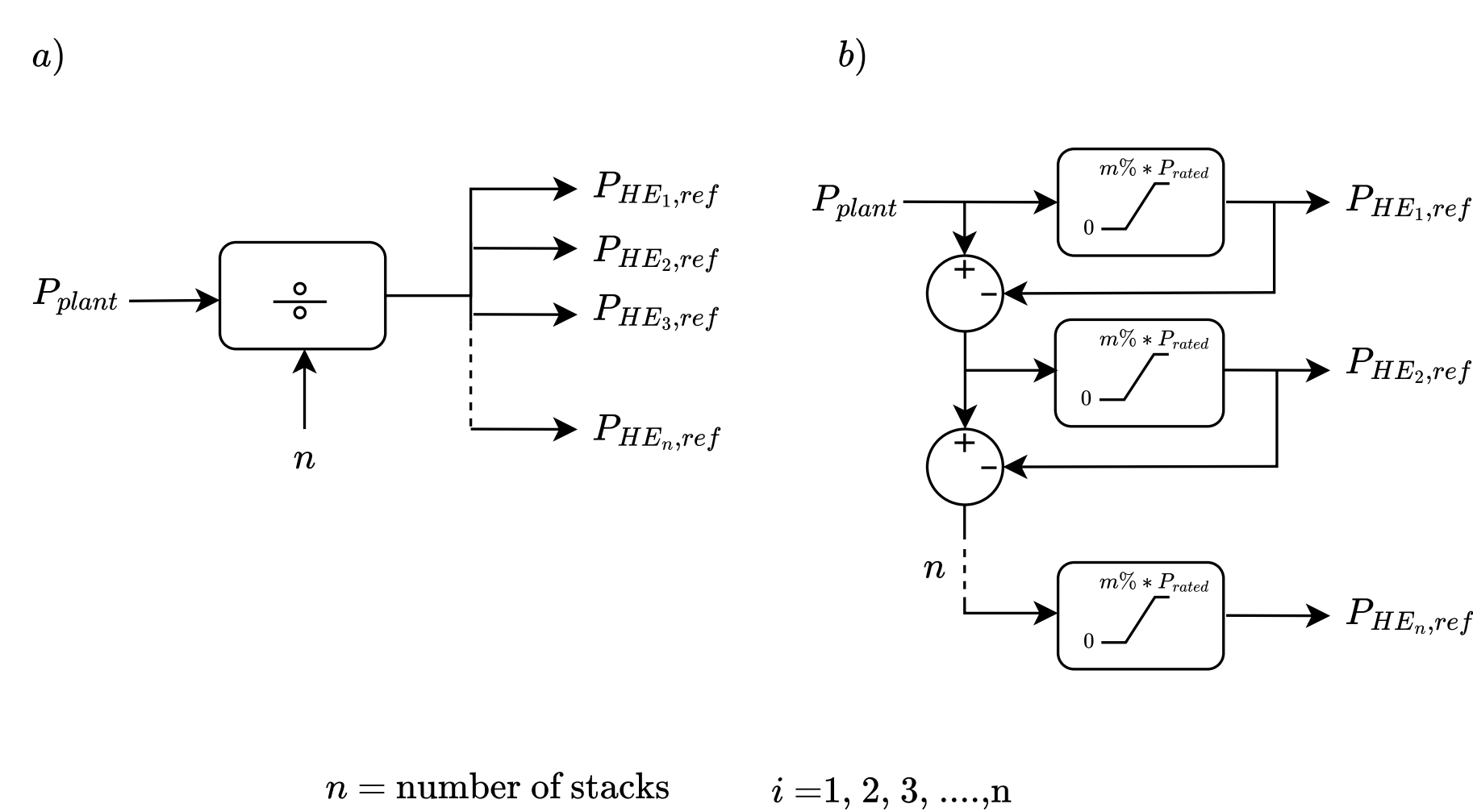

Figure 6: Power dispatch control strategy: a) average allocation, b) daisy-chain allocation.

6. Experimental Results

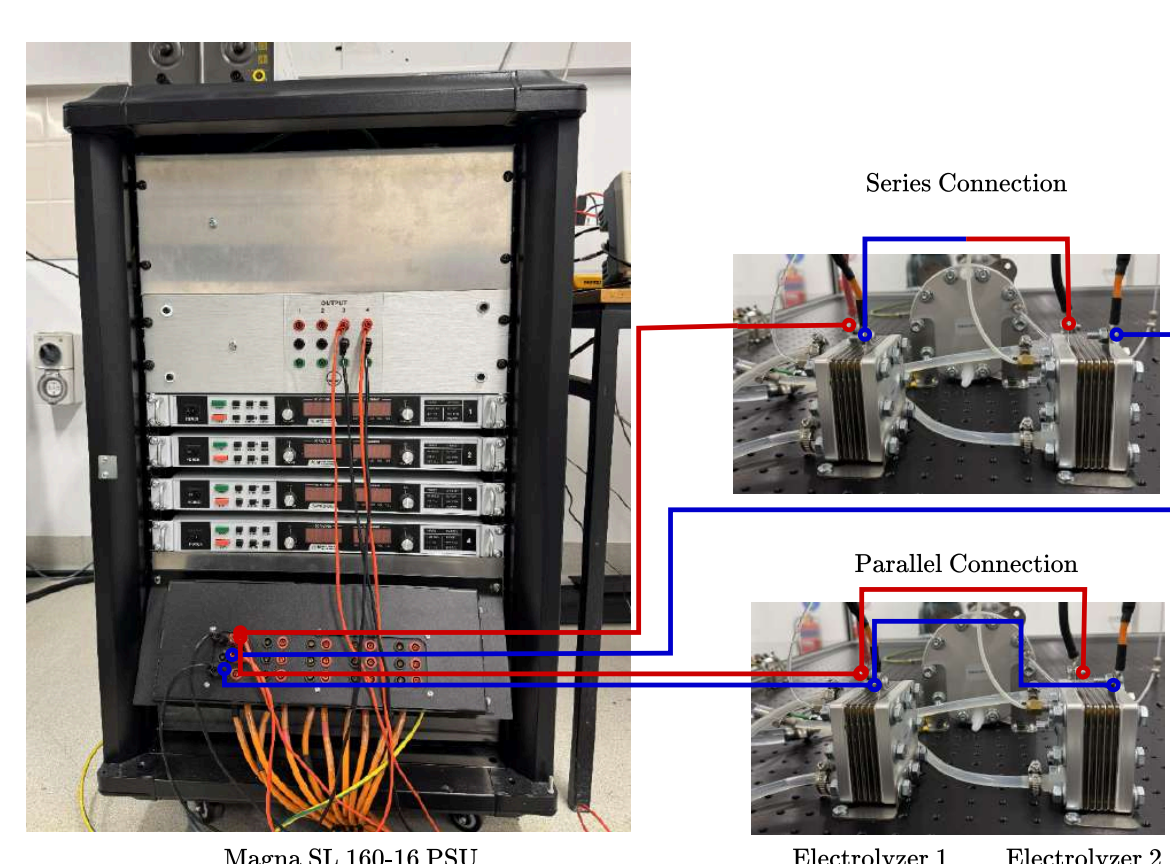
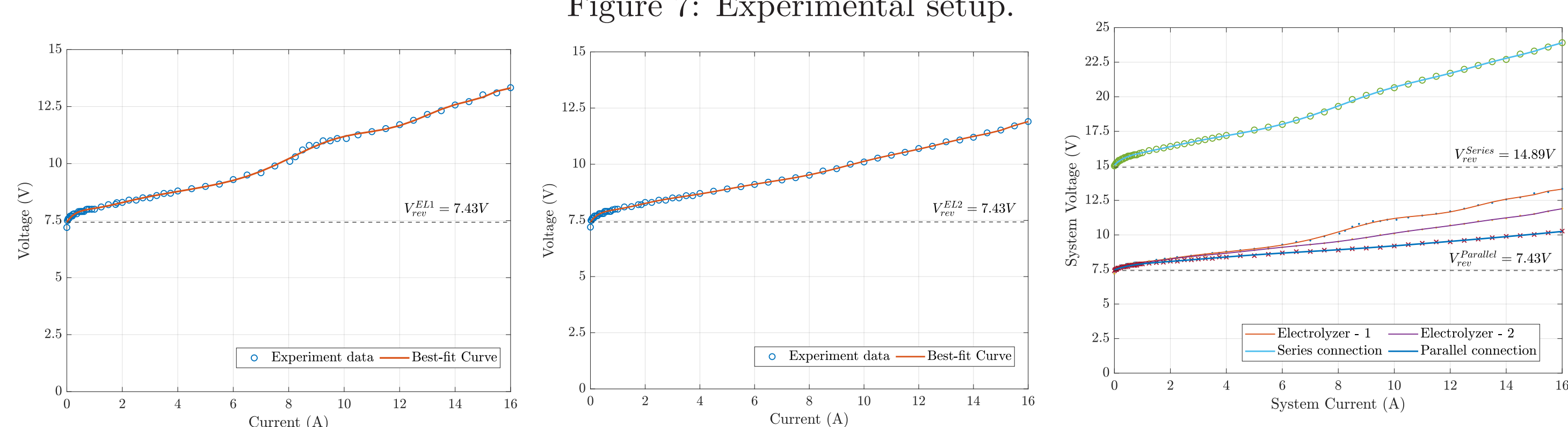

Figure 7: Experimental setup.



(a) Polarization curve-Electrolyzer 1. (b) Polarization curve-Electrolyzer 2. (c) System polarization curve for series and parallel connections.

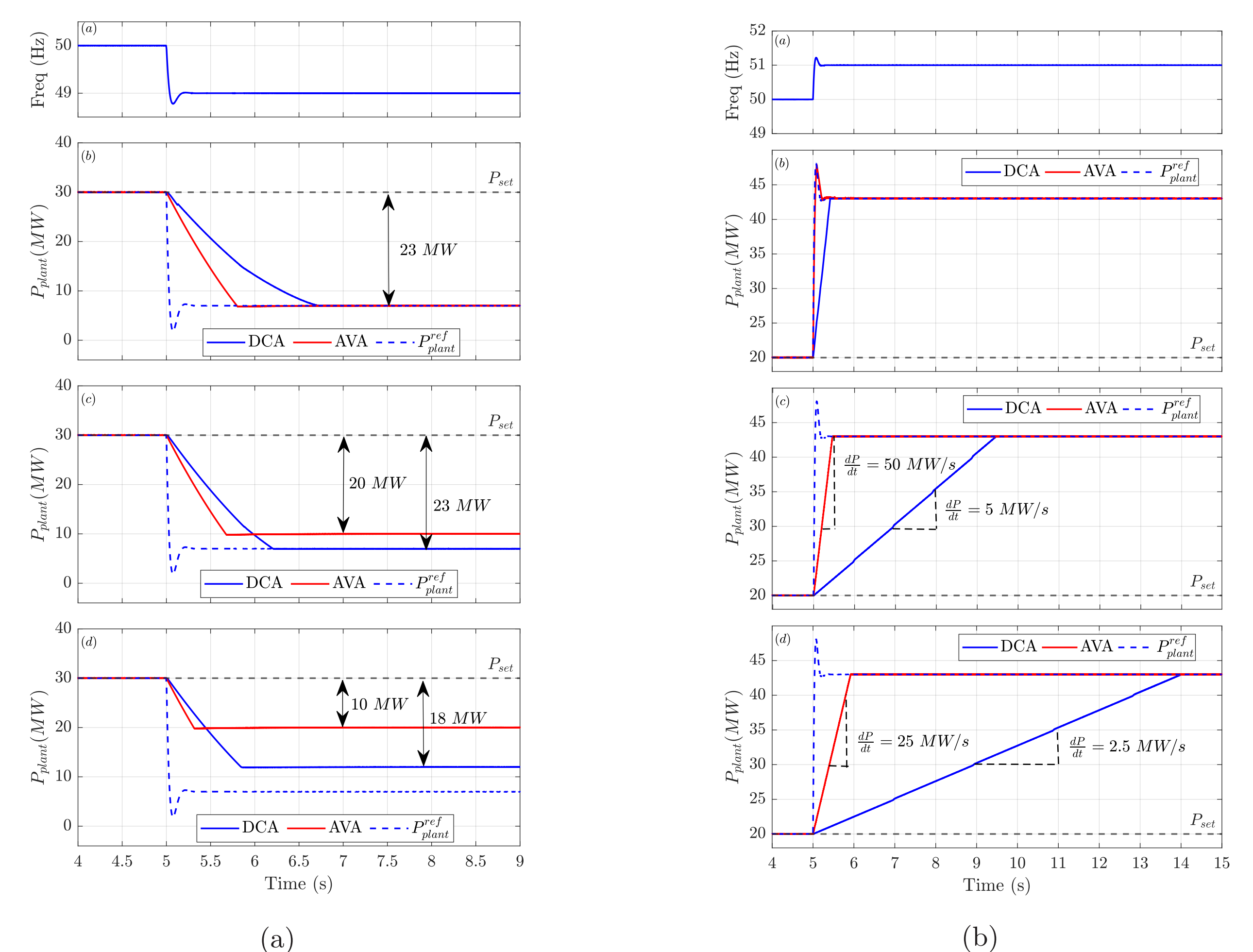

Figure 5: Power dispatch strategy impacts on, (a) HE frequency response volume and the whole-plant partial load limit, (b) HE frequency response speed and the whole-plant ramp rate limit.

7. Conclusions

1. System V-I characteristics vary significantly with the different stack interconnection topologies.
2. The selection of a power allocation strategy has a significant impact on overall plant efficiency, partial load limit, and the aggregate ramp rate limit.
3. Adopted power dispatch strategy significantly influences the system frequency response following grid disturbances.
4. Power electronics requirements also differ according to different interconnection strategies and power dispatch methods.