

Transient Stability of Grid-Forming Inverters

Huy-Ngoc Duong*, Mohammad Hasan Ravanji, and Behrooz Bahrani

Department of Electrical and Computer Systems Engineering, Monash University, Melbourne, Australia

huy.duong1@monash.edu

1. Introduction

- Power systems are undergoing a transition from traditional synchronous generators to inverter-based resources.
- Grid-forming inverters (GFMI)** are a promising solution for providing synthetic inertia, black-start capability, islanded operation, and reliable performance under weak-grid conditions.
- However, unlike synchronous generators, which can supply fault currents up to 3–5 per-unit (pu), GFMI are typically limited to **1.2–1.5 pu**.
- Therefore, a **current limiter** is a necessary control component in GFMI and has a **significant impact** on their **transient stability**.
- This poster proposes a framework for estimating the transient stability margin of GFMI under the influence of current limiters.
- Equal Area Criteria** and **Lyapunov's Direct Method** are developed for application to GFMI equipped with current limiters.
- The **estimation error** of the proposed methods is **less than 20%**, as benchmarked against **Experimental** results.

2. Transient Stability Assessment Framework

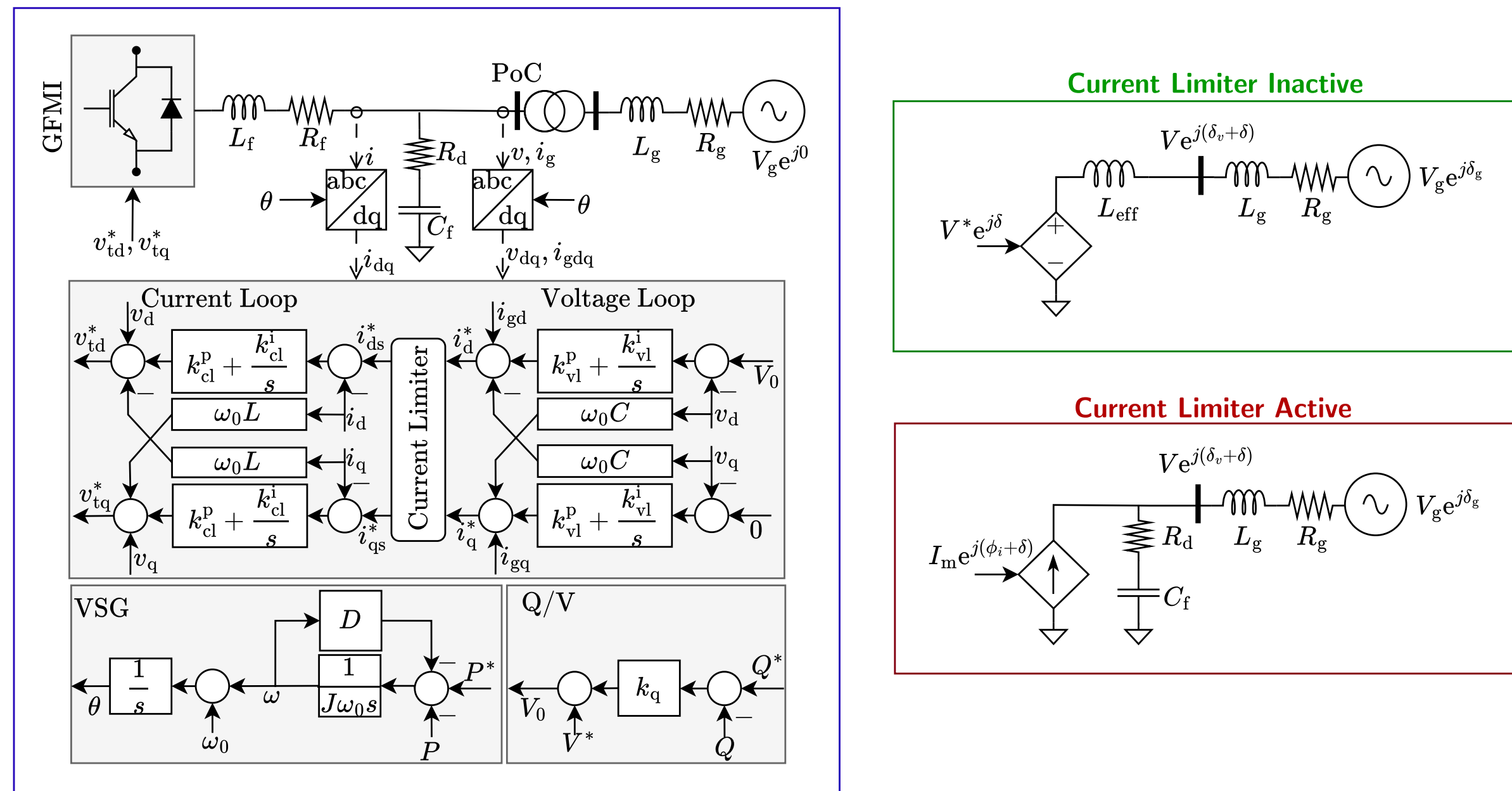

Figure 1: Dual-cascaded control scheme and equivalent circuits for a GFMI equipped with a current limiter.

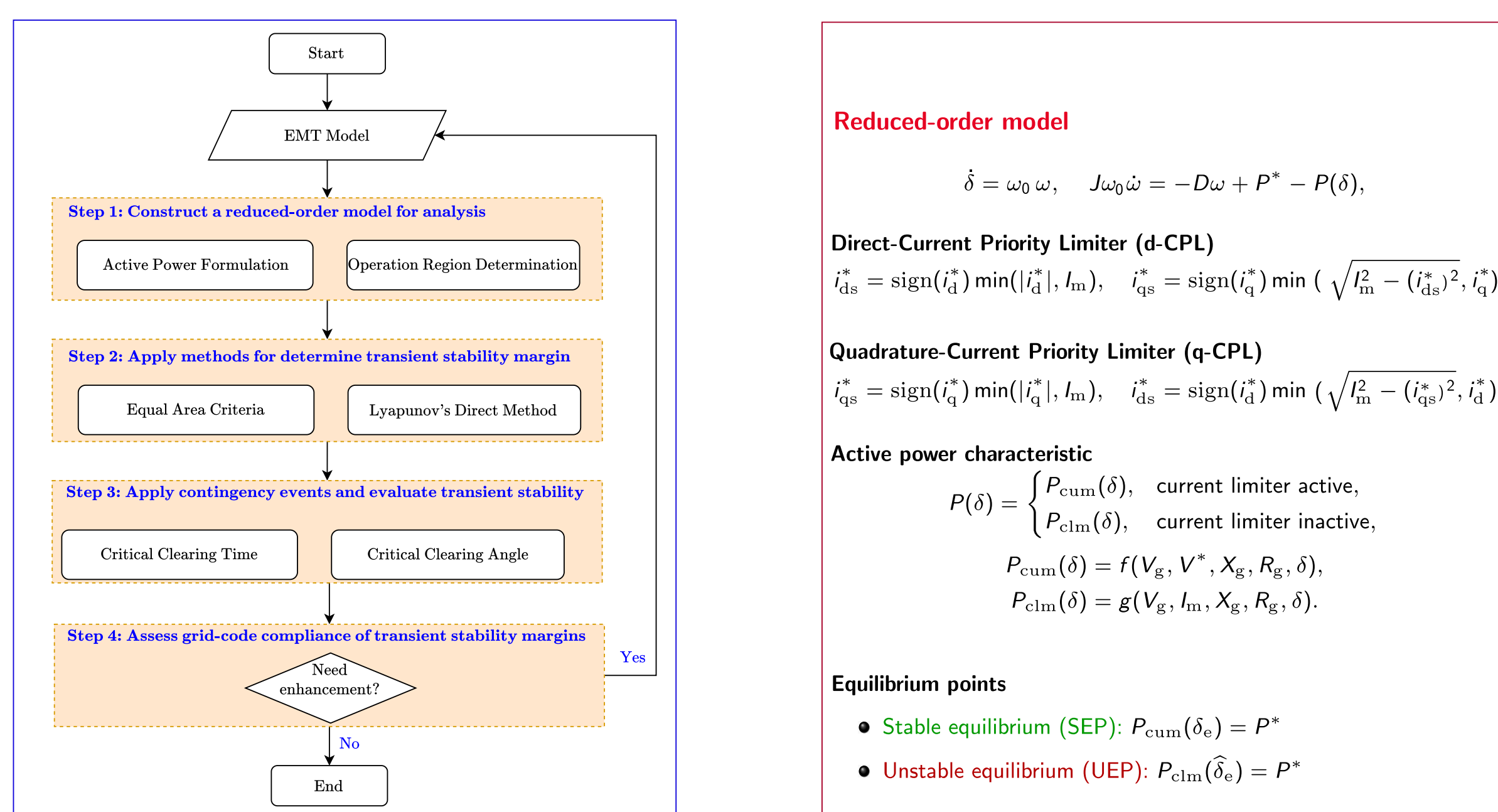

Figure 2: Flowchart and reduced-order model for transient stability analysis of GFMI.

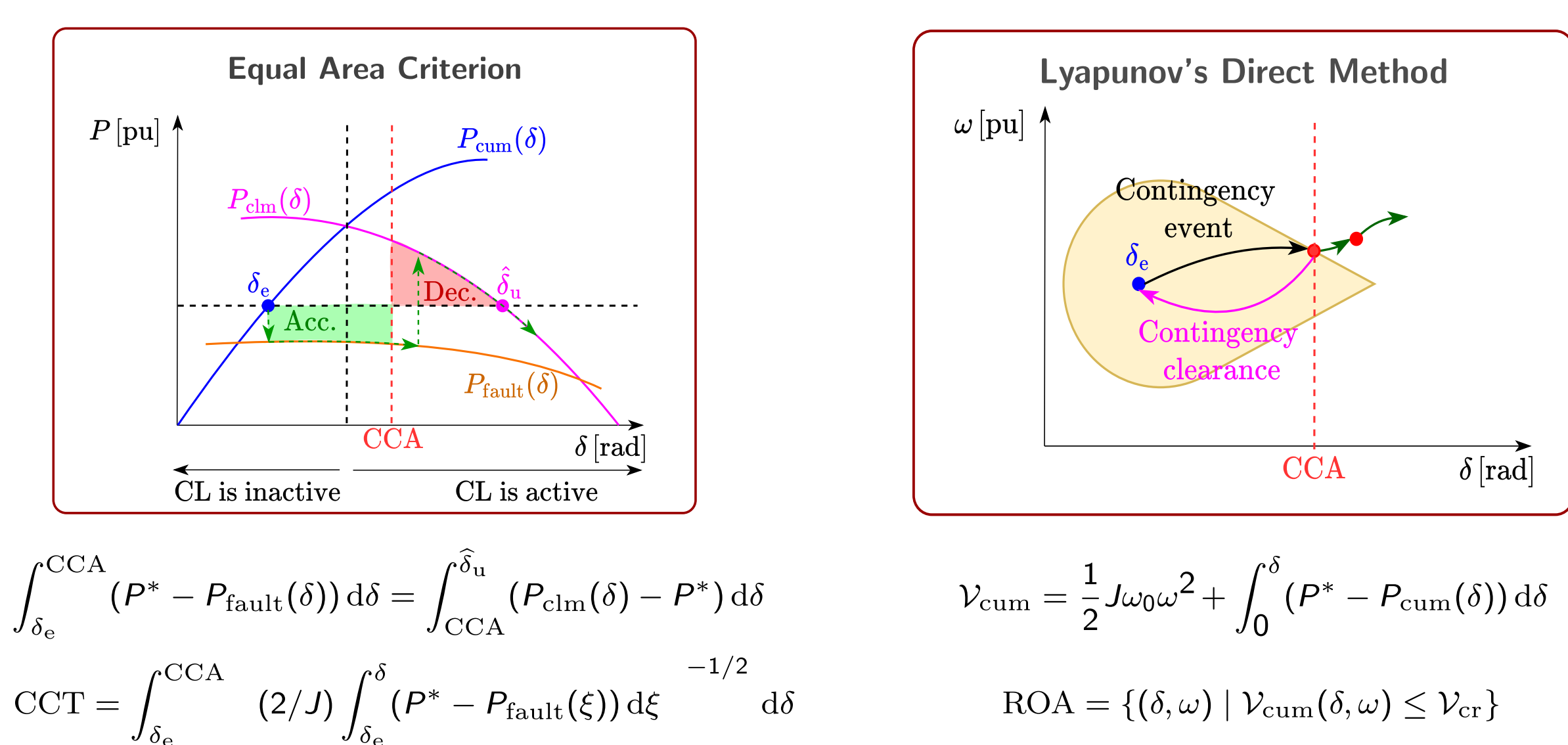

Figure 3: Equal area criterion and Lyapunov's direct method for estimating the transient stability margin.

3. Experimental Setup

- Regatron AC.TCS Power Supply acts as a grid voltage emulator.
- Imperix Inverter (1.5 kVA, 110 V, 10 kHz) functions as a GFMI.
- iTECH-500-40 DC Supply provides a constant DC voltage for the inverter.
- Other physical components are impedance, sensors, and monitoring.

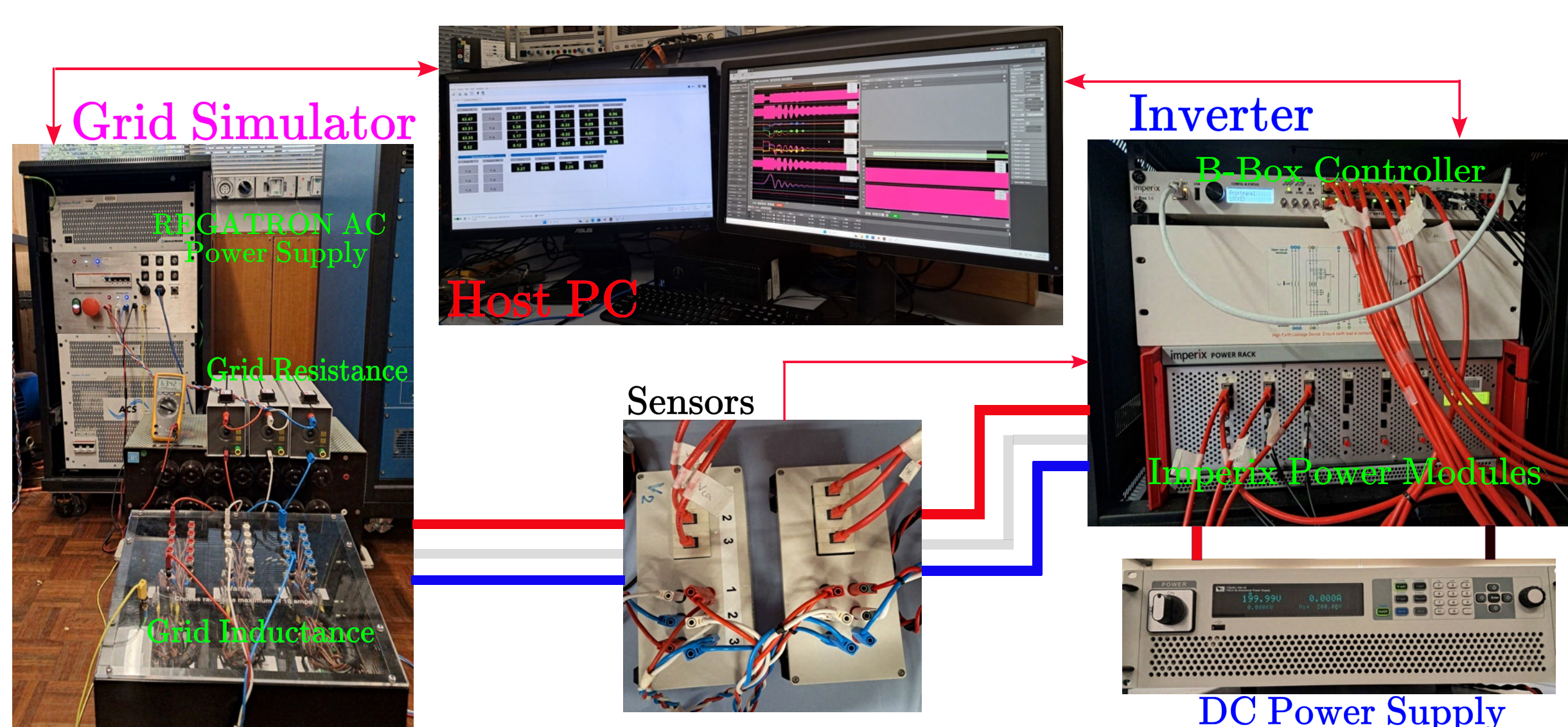

Figure 4: Experimental Setup.

4. Estimation of Transient Stability Margin

Estimated Critical Clearing Angle (SCR = 6.3):

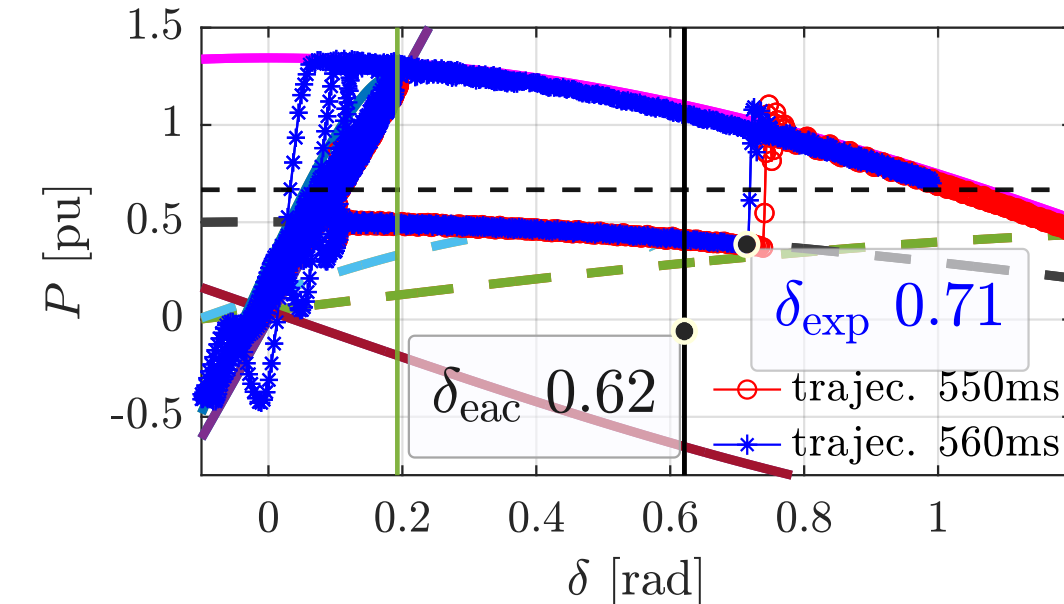

Figure 5: Estimated stability margin (SCR = 6.3).

Experimental Response (SCR = 6.3):

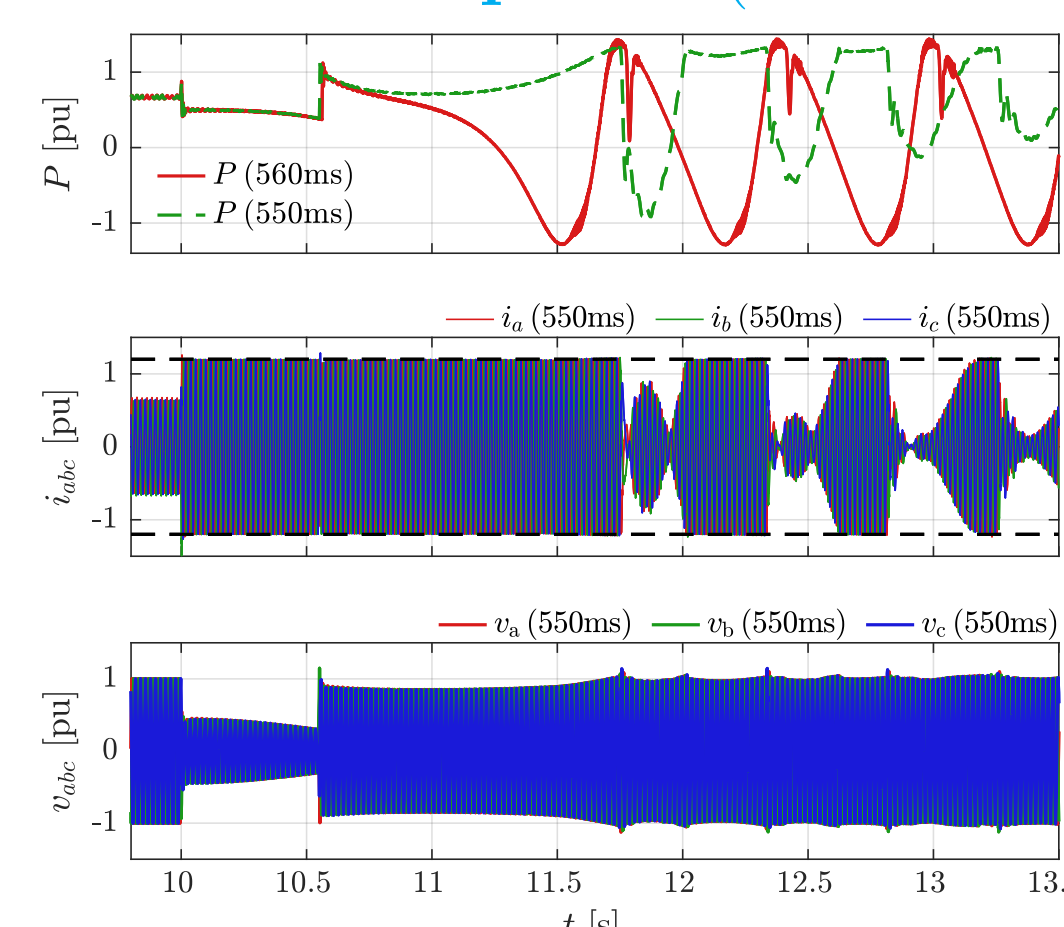

Figure 6: Experimental response (SCR = 6.3).

Estimated Critical Clearing Angle (SCR = 2.5):

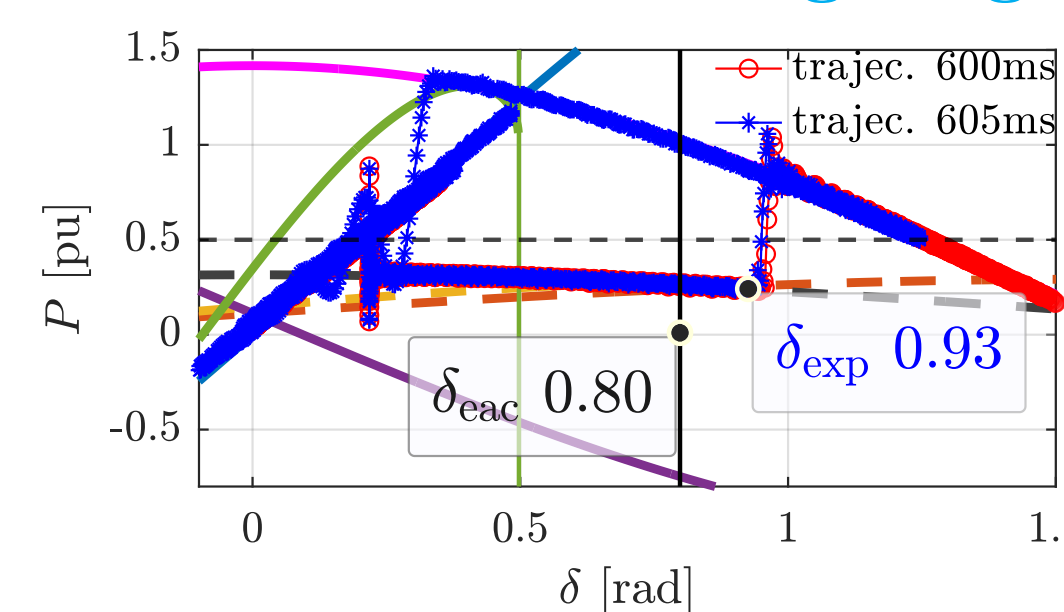

Figure 7: Estimated stability margin (SCR = 2.5).

Experimental Responses (SCR = 2.5):

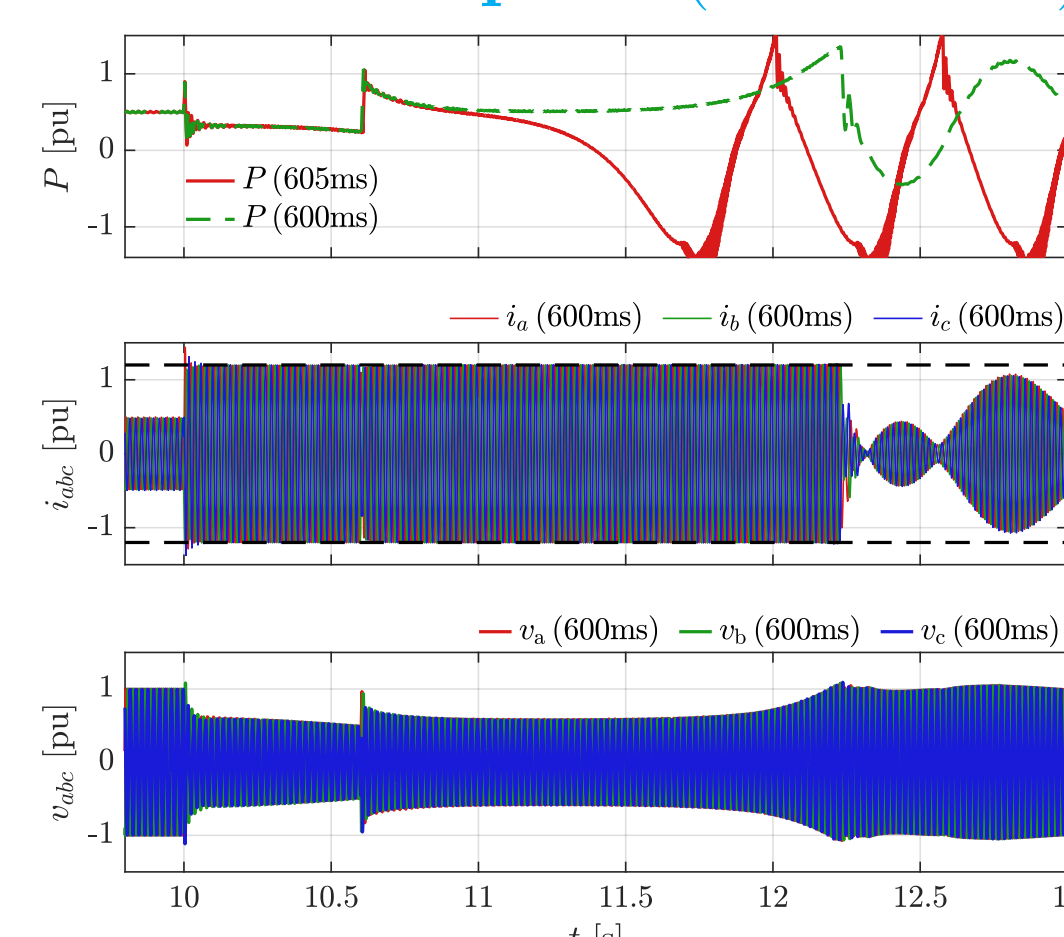

Figure 8: Experimental response (SCR = 2.5).

Critical Clearing Time under Different Current Limiter Types:

SCR	q-CPL		d-CPL	
	no/with r_{st}	no r_{st}	no r_{st}	with r_{st}
8.39 ($V_{gr}^f = 0.35$ pu)	≤ 55	65	582	
6.29 ($V_{gr}^f = 0.35$ pu)	≤ 81	80	550	
5.04 ($V_{gr}^f = 0.15$ pu)	≤ 172	108	418	
2.52 ($V_{gr}^f = 0.15$ pu)	≤ 258	172	602	
1.68 ($V_{gr}^f = 0.15$ pu)	≤ 384	265	602	

- d-PCL without r_{st} generally provides a lower transient stability margin.
- d-PCL with r_{st} provides a higher stability margin compared to q-PCL.

5. Conclusions

- A transient stability assessment framework for GFMI equipped with current limiters is presented.
- Equal-area criteria and Lyapunov's direct method can be applied to GFMI with current limiters, with careful consideration of the current-limited mode.
- Equal-area criteria is used to estimate the stability margin, showing an estimation error of 15–20%.
- Future work includes extending the framework to large-scale inverter-dominated systems and developing black-box models for transient stability analysis.

References

- Australian Energy Market Commission (AEMC), "NER version 236, Clause S5.2.5.5a: Responses to Disturbances Following Contingency Events," <https://bit.ly/4s6veqB>, 2025.
- VDE FNN, "Technical Connection Rules for High-Voltage (VDE-AR-N 4120)," <https://bit.ly/496ggIp>, 2018.
- B. Bahrani, M. H. Ravanji, B. Kroposki, D. Ramasubramanian, X. Guillaud, T. Prevost, and N.-A. Cutululis, "Grid-forming inverter-based resource research landscape: Understanding the key assets for renewable-rich power systems," *IEEE Power and Energy Magazine*, vol. 22, no. 2, pp. 18–29, 2024.
- S. P. Me, M. H. Ravanji, B. Leonardi, D. Ramasubramanian, J. Ma, S. Zabihi, and B. Bahrani, "Transient stability analysis of virtual synchronous generator equipped with quadrature-prioritized current limiter," *IEEE Trans. on Power Electronics*, vol. 38, no. 9, pp. 10 547–10 553, 2023.